



Next Generation 3000 series

Aerospace Pressure Sensors – millivolt

The Next Generation 3000 series (NG3000) platform, provides a robust technical and cost effective solution. The product has been designed and qualified to satisfy the demands within both Commercial and Military Aviation, whilst also being suited to the developing markets within Advance Air Mobility (AAM) and Space launch vehicles. The products are an evolution of the field proven PTX/PMP3000 platform, which launched in the year 2000. Druck Aerospace has been supplying the industry for more than 30 years, with a large installed base on many of the world's prestigious programs. The lessons learned throughout this period, combined with the latest designs and processes, has enabled the technology improvements to be made to offer this fully configured COTS solution. The benefits of the COTS product helps reduce the need for expensive qualification testing and lengthy development cycles, whilst also supporting smaller program needs. The product range has been stringently tested and qualified in accordance with the most current RTCA DO-160G and Mil. standards for airborne equipment, with additional levels of testing beyond these requirements to ensure that our products will perform for the wider range of applications.

The product variants are designed to fulfill a complete range of applications performing in the harshest of environments including but not limited to:

- Engine
- Hydraulic actuation
- Environmental Control Systems (ECS)
- Auxiliary Power Units (APU)
- Fuel
- Cooling/heating systems
- Unmanned airborne vehicles
- Test

Technical Features of this product

- Qualified to the latest airborne equipment requirements
- Fully analogue (no micro processors)
- Excellent accuracy and stability performance
- Standard and extended temperature ranges available
- Dual and single channel variants
- Fully hermetically sealed
- Low mass
- Wide range of pressure and electrical interfaces
- Pressure ranges from 350 mbar (5 psi) up to 700 bar (10150 psi) Full-Scale (FS).
- Gauge/Sealed Gauge (SG), Differential and Absolute
- High pressure overload protection

General Specification

- Selectable 5 Vdc or 10 Vdc power supply (sensor output is ratiometric to the supply voltage).
- Zero offset available up to 10 mV for 10 V supply and 5 mV for 5 V supply.
- Standard Operating Temperature Range -55°C to +150°C (-67°F to +302°F) for pressure ranges starting at 350 mbar (5 psi).
- Extended Operating Temperature -55°C to 177°C (-67°F to 351°F) for pressure ranges starting at 700 mbar (10 psi).
- Qualified to RTCA DO-160G (qualification report available upon approved request).
- Insulation Resistance: >500 MΩ at 750 Vdc between all pins connected together and case. The test is also applied channel to channel for Dual Channel sensors.
- Dielectric Strength: <1 mA leakage current at 1061 Vac RMS between all pins connected together and case. Single Channel variant only.
- Dielectric Strength: <1 mA leakage current at 750 Vac RMS between all pins connected together and case. Dual Channel variant only.
- Electrical interface via 4/5/6 pin connectors (Single Channel), 8/10/12 pin connectors (Dual Channel).
- Input impedance
Standard Operating Temperature: 20 kΩ typical
Extended Operating Temperature: 1.4 kΩ typical
- Output impedance
Standard Operating Temperature: 5.3 kΩ typical
Extended Operating Temperature: 600 Ω typical
- Response time: < 0.5 ms

Accuracy

		Temperature range	Total accuracy ¹	
			Press range ≤ 1 bar	Press range > 1 bar
Extended temperature range	Standard temperature range	-55°C to -20°C (-67°F to -4°F)	±3.0% FS	±1.5% FS
		-20°C to +90°C (-67°F to +194°F)	±1.0% FS	±1.0% FS
		+90°C to +125°C (+194°F to +257°F)	±2.0% FS	±1.5% FS
		+125°C to +150°C (+257°F to +302°F)	±3.0% FS	±2.0% FS
	Extended temperature range	+125°C to +177°C (+257°F to +351°F)	±3.0% FS	±2.0% FS

Long term stability < ±0.15% Full-Scale Max over 5 years

¹ Includes the effects of non-linearity, hysteresis, zero, span and thermal effects

Wiring Details

Single Channel: 4/5/6 pin output options

Connector Pin	Function
A/1	Output positive
B/2	Output negative
C/3	Supply negative
D/4	Supply positive
E/5	Not connected
F/6	Not connected

Dual Channel: 8/10/12 pin output options

Connector Pin	Function	Channel
A/1	Output positive	Channel A
B/2	Output negative	
C/3	Supply positive	
D/4	Supply negative	
E/5	Output positive	Channel B
F/6	Output negative	
G/7	Supply positive	
H/8	Supply negative	
J/9	Not connected	N/A
K/10	Not connected	
L/11	Not connected	
M/12	Not connected	

Differential Pressure Sensor

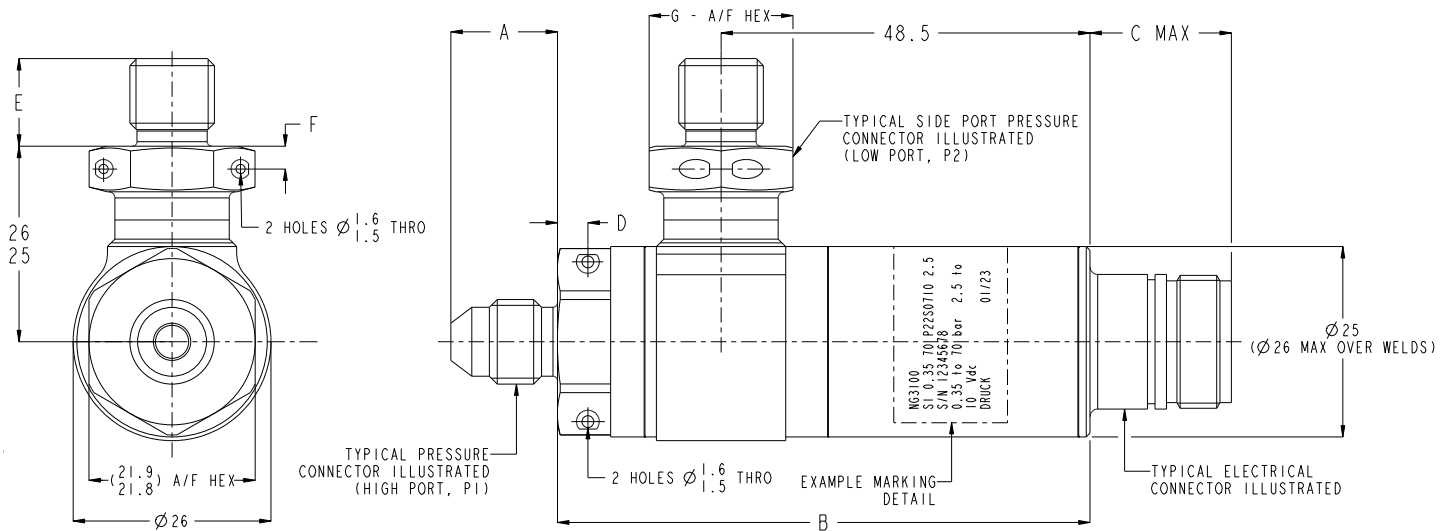

All dimensions are in mm

Configuration	A±1*	B±1*	C Max*	D±0.2*	E±0.2*	F±0.2*	G±0.05
All pressure ranges	15.5 mm	70 mm	19.9 mm	5 mm	15.5 mm	5 mm	21.85 mm

* All dimensions are max. based on variable options

The differential pressure sensor is semi-isolated by design. The High Pressure port is denoted as P1, and is fully isolated from the pressure media. The Low Pressure port is denoted as P2, with the pressure sensing silicon exposed to the media. See specification document 158M5591 for compatibility information.

This product should only be used where the media is known and is proven to be compatible with the silicon and adhesive used on the low pressure port.

Line pressure is the static pressure applied to both ports.

Performance

- Single Channel variant.
- Low pressure bi-directional ranges available
- 5 to 1015 psi (350 mbar to 70 bar) Differential (Standard Operating temp. range)
- 10 to 1015 psi (700 mbar to 70 bar) Differential (Extended Operating temp. range)
- Proof pressure P1 = 2 x FS
- Burst pressure P1 = 2.3 x FS
- Proof pressure P2 = 2 x FS up to a maximum of 18 bar
- Burst pressure P2 = 20.7 bar
- Line pressure to 70 bar
- Line proof = 2 x Differential line pressure
- Line burst = 2.5 x Differential line pressure (up to a maximum of 140 bar)
- Pressure media:
 - P1 fluids and gases compatible with 316L stainless steel
 - P2 fluids and gases compatible with 316L stainless steel, glass, silicon and adhesive
- Mass <275 g (Max)

Gauge/Sealed Gauge/Absolute Pressure Sensor

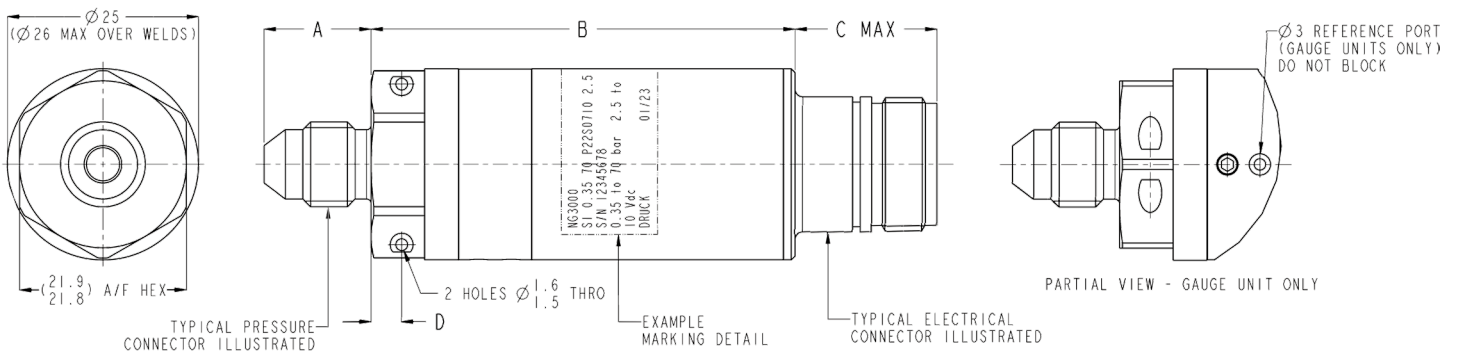

All dimensions are in mm

Configuration	A±1*	B±1*	C Max*	D±0.2*
Single Channel Abs./SG	15.5 mm	50.5 mm	19.9 mm	5 mm
Single Channel Gauge		55.5 mm		
Dual Channel Abs.		50.5 mm		
Dual Channel Gauge		53.7 mm		
High Pressure Abs./SG		53.5 mm		

* All dimensions are max based on variable options.

Gauge is referenced to the atmospheric pressure.

Sealed gauge is referenced to vacuum with the silicon not exposed to application media. Sensor is calibrated to gauge pressure.

Absolute is referenced to zero atmospheric pressure.

Performance

- Single or Dual Channel offering
- 350 mbar to 700 bar Absolute (5 psi to 10150 psi). Single Channel variant only.
- 70 bar to 700 bar Sealed Gauge (1015 psi to 10150 psi). Single Channel variant only.
- 350 mbar to 70 bar psi Absolute or Gauge (5 to 1015 psi). Single or Dual Channel variants.
- Minimum span and operating pressure for extended temperature variant is 700 mbar (10 psi).
- Proof Pressure
 - 0 to 70 bar, 2 x FS (Max. 5 mins)
 - >70 bar to 700 bar, 1.5 x FS (Max. 5 mins to a maximum 700 bar)
- Burst Pressure
 - Absolute
 - 140 bar for 0 to 70 bar FS
 - 300 bar for >70 bar to 120 bar FS
 - 750 bar for >120 bar to 300 bar FS
 - 1400 bar for >300 bar to 700 bar FS
 - Sealed Gauge
 - 300 bar for ≥70 bar to 120 bar FS
 - 750 bar for >120 bar to 300 bar FS
 - 1400 bar for >300 bar to 700 bar FS
 - Gauge
 - 2.3 x Full-Scale up to a maximum of 140 bar
- Pressure Media: Absolute or Sealed Gauge, for use with fluids and gases compatible with 316L stainless steel, 17-4PH stainless steel, Inconel 625
- Gauge
 - Front Port: For use with fluids and gases compatible with 316L stainless steel
 - Reference Port: For use with fluids and gases compatible with 316L stainless steel, glass, silicon and adhesive
- Mass <175 g (Max).

Part Numbering and String Configuration

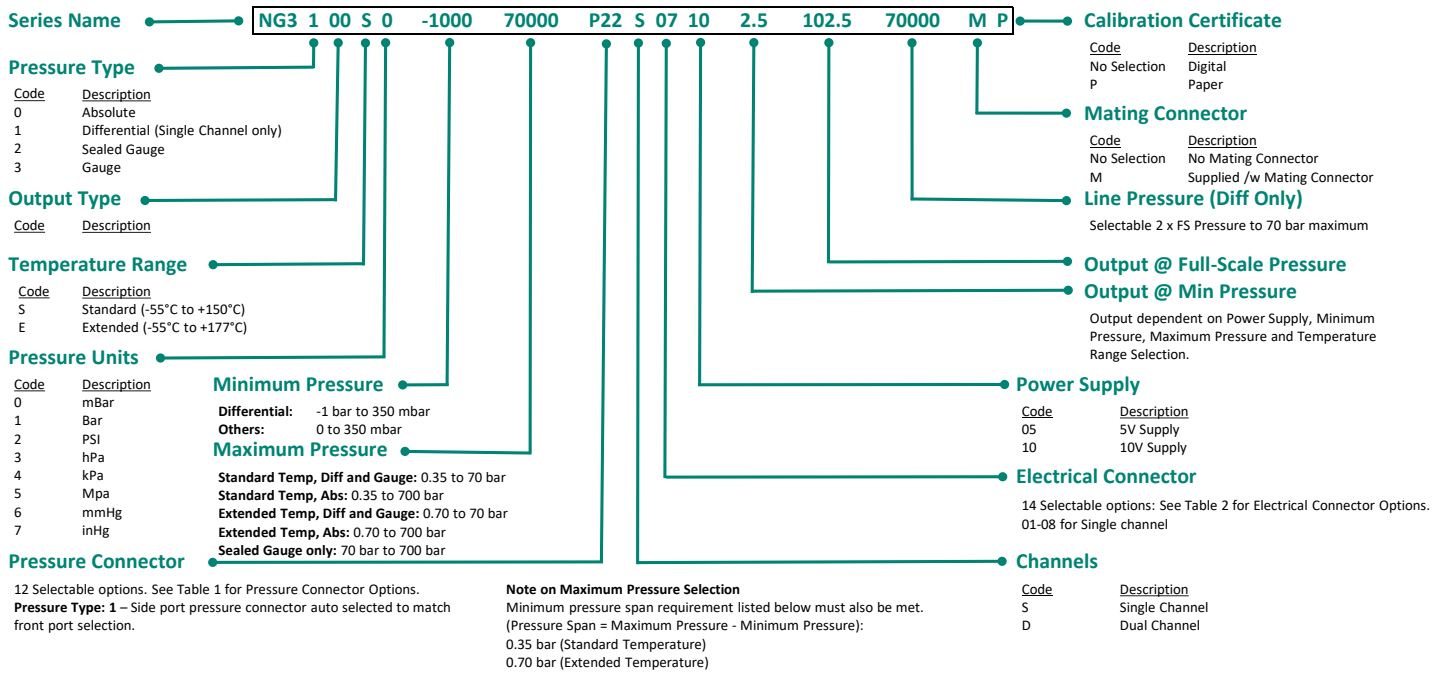

Reference	Description
P22	7/16–20 UNF Flat End 74°
PL	7/16–20 UNJF Male 74° Ext
P40	7/16–20 UNJF MS33656-4
P44	7/16–20 UNJF MS33514-4
P45	7/16–20 UNJF MS33656-4
P46	7/16 UNJF 24° MS33514-4
P41	G1/4 Male 60° Int. W/L
PA	G1/4 Female
PI	M10 x 1 60° Int Wirelock
PZ	M10 x 1 80° Int. Cone
RD	M12 x 1 74° Ext. Wirelock
P48	MJ12x1.25 24° Int Cone
PI3	M14 x 1.5 60° Int W/lock
P30	7/16–20 UNJF–3A
P63	9/16 UNJF Male 24° MS33514E6

Reference	Description
01	EN2997Y1 10-05MN
02	EN2997Y1-10-05M6
03	MIL-C-83723-10-05PN
04	EN2997Y1-10-06MN
05	MIL-C-38999-A-35PN
06	MIL-C-38999-B-98PN
07	MIL-C-26482-10-06PN
08	MIL-C-26482-08-04PN
09	EN2997Y1-12-12MN
10	EN2997Y1-12-12M6
11	MIL-C-38999-C-98PN
12	MIL-C-38999-C-98PA
13	MIL-C-83723-12-12PN
14	MIL-C-26482-12-08PN

Part Marking (Standard)

NG3000	Configuration String
S1 0.35 70 P22S0710 2.5 102.5 MP	Configuration String
S/N 12345678	Serial Number
0.35 to 70 bar	Pressure Range, Units, and Output Range
10 Vdc	Power Supply
Druck	Manufacturer, Manufacture Month/Year
01/23	

Custom part marking can be accepted, details to be provided at the time of inquiry. Please see document 173M6849 for further detail.

Table 3 – Sensor Pressure Range Options

	Type	Minimum Pressure Range		Maximum Pressure Range		Minimum Span (MAX – MIN)
		Min	Max	Min FS	Max FS	
Standard Temperature (-55°C to +150°C)	Differential	-1 bar	350 mbar	350 mbar ¹	70 bar	350 mbar ¹
	Gauge	0	350 mbar	350 mbar ¹	70 bar	350 mbar ¹
	Sealed Gauge	0	350 mbar	70 bar	700 bar	69.650 bar
	Absolute	0	350 mbar	350 mbar ¹	700 bar	350 mbar ¹

¹ The minimum span and lower limit for maximum pressure is 700 mbar for extended temperature range variant.

Table 4 – Sensor Output Options

	Power Supply	Pressure Ranges (Span)	Output	
			Zero Offset	Span
			@ Minimum Pressure	
Standard Temperature (-55°C to +150°C)	5 V	≥350 mbar ≤700 mbar (>5 psi and ≤10 psi)	Selectable between 0 mV and 5 mV in 0.1 mV increment.	15 mV
		>700 mbar ≤1.4 bar (>10 psi and ≤20 psi)		35 mV
		>1.4 bar ≤700 bar (>20 psi and ≤10,150 psi)		Selectable between 45.0 mV to 50.0 mV
Extended Temperature (-55°C to +177°C)	5 V	>700 mbar ≤1.4 bar (>10 psi and ≤20 psi)	Selectable between 0 mV and 5 mV in 0.1 mV increment.	15 mV
		>1.4 bar ≤700 bar (>20 psi and ≤10,150 psi)		30 mV
		>1.7 bar ≤700 bar (>25 psi and ≤10,150 psi)		Selectable between 35.0 mV to 37.5 mV
	10 V	As above	Selectable between 0 mV and 10 mV in 0.1 mV increment.	x2 as above

Minimum Order Quantity (MOQ) is five (5) pieces of any single configuration.