



# DFI

## *DFI's Extreme Ruggedized Box PC Improves Operability and Efficiency for Intelligent Marine Fleet Management Systems*

### Overview

According to some research studies, over 90% of accidents at sea are due to human error. Two of fleet operations' most significant challenges are managing potential risks to ensure safety and optimizing fuel consumption. Seafarers face natural elements that can be difficult to predict and dangerous. Navigation skills are complex; anticipating conditions and responding correctly can be challenging. Any improper action, speed, or condition may increase the risk to crew and passengers. Modern computer technology has provided a tremendous step forward with intelligent solutions to better plan and monitor fleet operations.

Region: **Europe**

Industry: **Marine Vessel**

Application: **Marine Fleet Management System**

Solution: **ECX700-AL Ruggedized IP67 Grade Box PC**

# Challenges

---



## ***Stable Fleet Operation in Harsh Environment***

The computer system in or on the exterior of a vessel faces extreme exposure to the elements, salty sea water in particular. Electrical connections quickly corrode and fail when electronic circuitry is exposed to salt water. Hence, a system with a waterproof design is crucial to ensuring the vessel operates with stability and safety.



## ***High-Speed Connectivity***

Modern marine fleet management systems sync to the cloud so that data can be accessed anywhere in the world. For this reason, the industrial systems that fleet management software runs on must have high speed connectivity, such as 4G LTE and WiFi.



## ***Flexible Custom Design***

Marine fleet management systems are unique due to their ability to solve the challenges above. As integrators have specialized needs and often require modifications to their core products, a manufacturer with the resources and willingness to offer customization is essential.

# Solution

An intelligent navigation support system utilizes an automated vessel as an object of control, representing a structure consisting of navigation, power, and loading systems. The noticeable technological development in computer techniques and navigation systems comes with modern main engines and electric motor designs. Moreover, the product contributes to the increased reliability of the ship, not to mention the individual installation it operates.

The system monitors vessel behavior and environmental conditions. These actions improve predictions and provide adaptive and optimized speed, route, and decision support to enhance trip safety and efficiency.

DFI's ECX700-AL Ruggedized PC features an IP67-rated waterproof design and was integrated into an intelligent marine management system as a central control unit that collects and processes data from the onboard system. It presents output to a compatible multi-function display via Ethernet and uploads all data to a cloud platform through a 4G cellular network.

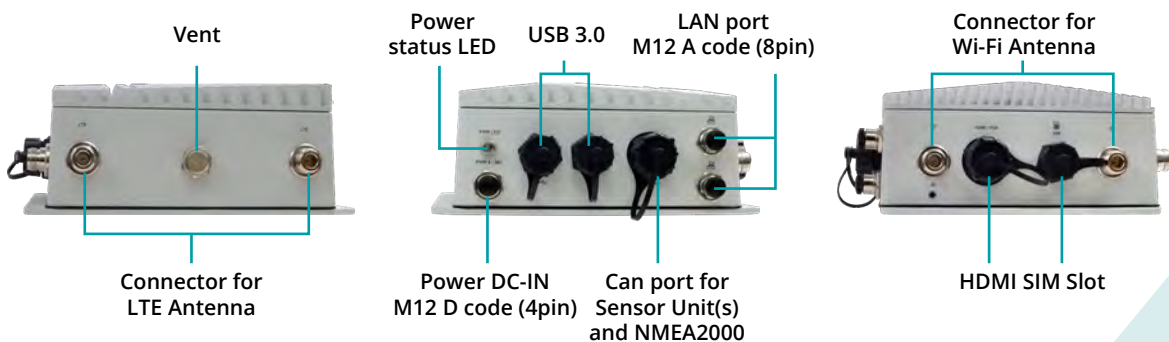

# Result

The Intelligent system solution improves safety for crew and passengers, limiting the risk of severe accidents and injuries. The marine system solution has demonstrated a capability to reduce fuel consumption and carbon emissions by up to 25%, reduce dangerous shocks and impact on board by up to 70% and reduce insurance premium policy discounts from selected insurers by up to 20%.

**25%**

**Fuel consumption and CO2 savings**



Protect people and equipment



Reduce fuel consumption

**70%**

**Reduction in wave slamming impacts**



Lower carbon footprint



Monitor vessel condition

**20%**

**Insurance premium savings**



Increase vessel lifespan



Train inexperienced operators

# About DFI's ECX700-AL



DFI's ECX700-AL Ruggedized Box PC is certified up to IP67 and supports industry-leading wide voltage and temperature to operate reliably outdoors. In addition, the system has waterproof connectors, further stopping any water from getting in. Due to the risks above to electronic circuitry from salt water, ECX700-AL's IP67 protection means that DFI's customers do not need to worry about electrical connections corroding or the overall system failing.

ECX700-AL has a full-size Mini PCIe slot for 4G LTE modules, an M.2 2230 for WiFi modules, two ports for WiFi antennas, and two ports for LTE antennas on the front and top I/O, respectively.

DFI offers customizable services, and ECX700-AL is no exception. For DFI's marine fleet management customer, modified cables were provided so the system could be easily integrated into the vessels' existing systems. Wire lengths, outlet types, and I/O holes are all customizable, allowing customers to configure them according to their needs by flexibly choosing from the WiFi and LTE modules. This rich product customization experience and mission-critical customer service make DFI the best-embedded solution partner.



## Conclusion

---

DFI provides a system that is ready out of the box, and its customers can successfully deploy their marine fleet management system and achieve reliable results in the field. The customer had no corrosion issues thanks to ECX700-AL's IP67 protection and the system's waterproof connectors. The system's 4G LTE and WiFi capability brings high-speed connectivity for data transmission to the cloud. Today, the marine fleet management system runs on DFI's hardware worldwide. The system provides the vessels with the essential information they need to operate efficiently and reach their destination safely and on time.

## ECX700AL-Waterproof Test Video

---

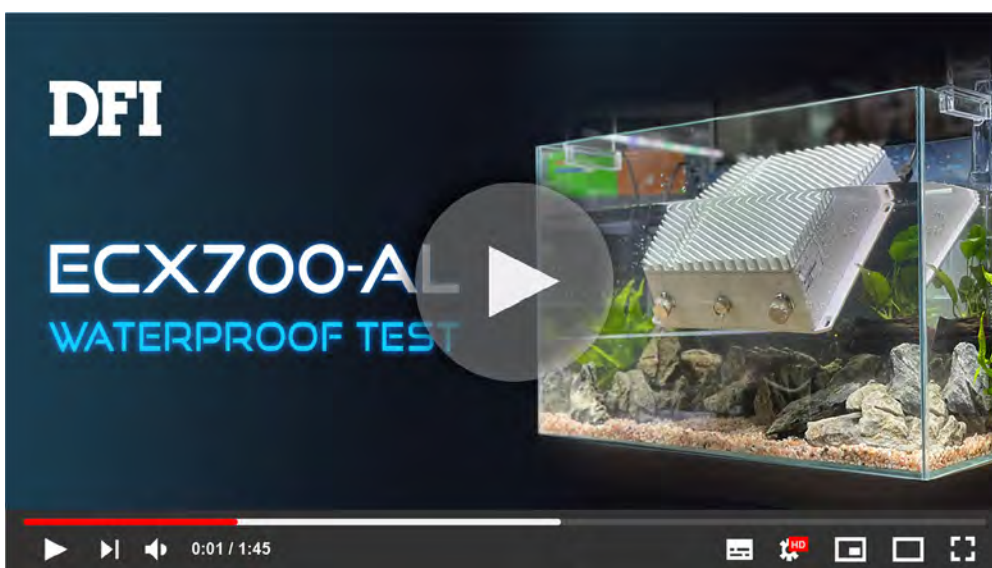

# DFI

Founded in 1981, DFI is a global leading provider of high-performance computing technology across multiple embedded industries. With its innovative design and premium quality management system, DFI's industrial-grade solutions enable customers to optimize their equipment and ensure high reliability, long-term life cycle, and 24/7 durability in a breadth of markets including factory automation, medical, gaming, transportation, smart energy, defense, and intelligent retail.

Website: [www.dfi.com](http://www.dfi.com)

Inquiry: [inquiry@dfi.com](mailto:inquiry@dfi.com)

---

Copyright © 2021 DFI Inc. All rights reserved. DFI is a registered trademark of DFI Inc. All other trademarks are the property of their respective owners.

*For more information, please contact your DFI regional sales representative or send us an email: [inquiry@dfi.com](mailto:inquiry@dfi.com)*