

PICO-IMX8M-MINI

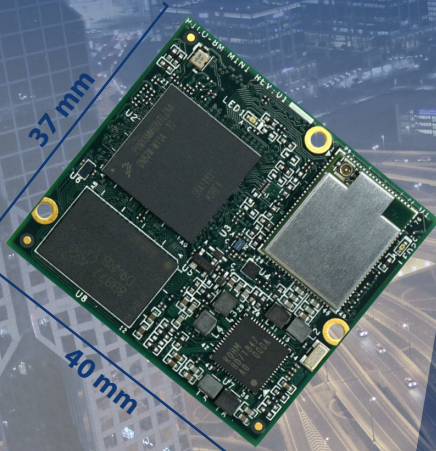

- The PICO-IMX8M-MINI is a System on Module (SOM) based on an NXP i.MX8M Mini Quad core Cortex-A53™ + M4™ processor clocking up to 1.8GHz.
- The PICO-IMX8M-MINI operates in commercial and industrial temperature ranges from -40 to 85°C. The on-board Vivante GC NanoUltra, OpenGL ES 2.0 supports Full-HD MIPI DSI display and MIPI-CSI2 Camera. The OpenCL GPU accelerator brings up-to 32 GOPS AI/ML capabilities to IIoT edge devices.
- The PICO-IMX 8M-MINI is a member of the TechNexion “PICO pin-to-pin” product family, providing scalable embedded solutions with industrial interfaces such as RGMII, USB, I²S, UART, SPI, I²C, PWM, GPIO for sensors for IIoT edge devices.
- Accelerate your time-to-market and reduce development costs with TechNexion pre-certified FCC / IC / CE / RCM / TELEC dual-band Wi-Fi 802.11 ac/a/b/g/n, Bluetooth.
- Linux, Yocto, Android runtime images and full source code available.

Specifications



Core System

Processor	NXP i.MX8M Mini Quad
Processor Speed	up to 1.8GHz
Architecture	ARM Cortex-A53 + M4
PMIC	ROHM BD71847
Memory	up to 4GB LPDDR4
Storage	eMMC (16GB Default)
Board-to-Board Connector	Edison compatible connector PICO 70-pin Hirose connectors
System on Module	PICO SOM

Connectivity

Network LAN	RGMII
Wi-Fi/Bluetooth	Qualcomm QCA9377
Antenna	802.11 a/b/g/n/ac + BT (BR+EDR+BLE) MHF4 connector

Signaling

I/O	MIPI CSI	I ² S
	MIPI DSI	SDIO
	RGMII	UART
	PCIe	SPI
	USB	I ² C
	USB OTG	PWM
		GPIO

Video

Graphic Engine	Vivante GC Nano Ultra
Video Decode	1080p60 H.264
Video Encode	1080p60 H.264
Camera	MIPI CSI (4 lanes)

Audio

Audio Codec	On carrier board
Audio Interface	I ² S (2 channel)

Operation Systems

Standard Support	Linux
	Yocto
	Android

Certification and Compliance

USA	FCC ID: 2AKZA-QCA9377
Canada	IC: 22364-QCA9377
Japan	TELEC: 201-180629
European Union	EN 55032 / EN 55024 EN 300 328 v2.2.2 EN 301 893 v2.1.1
Australia/New Zealand	RCM
Bluetooth Logo	QDID150839 (Bluetooth 4.2)
Certification	Compliant with RoHS / REACH directives

Block Diagram

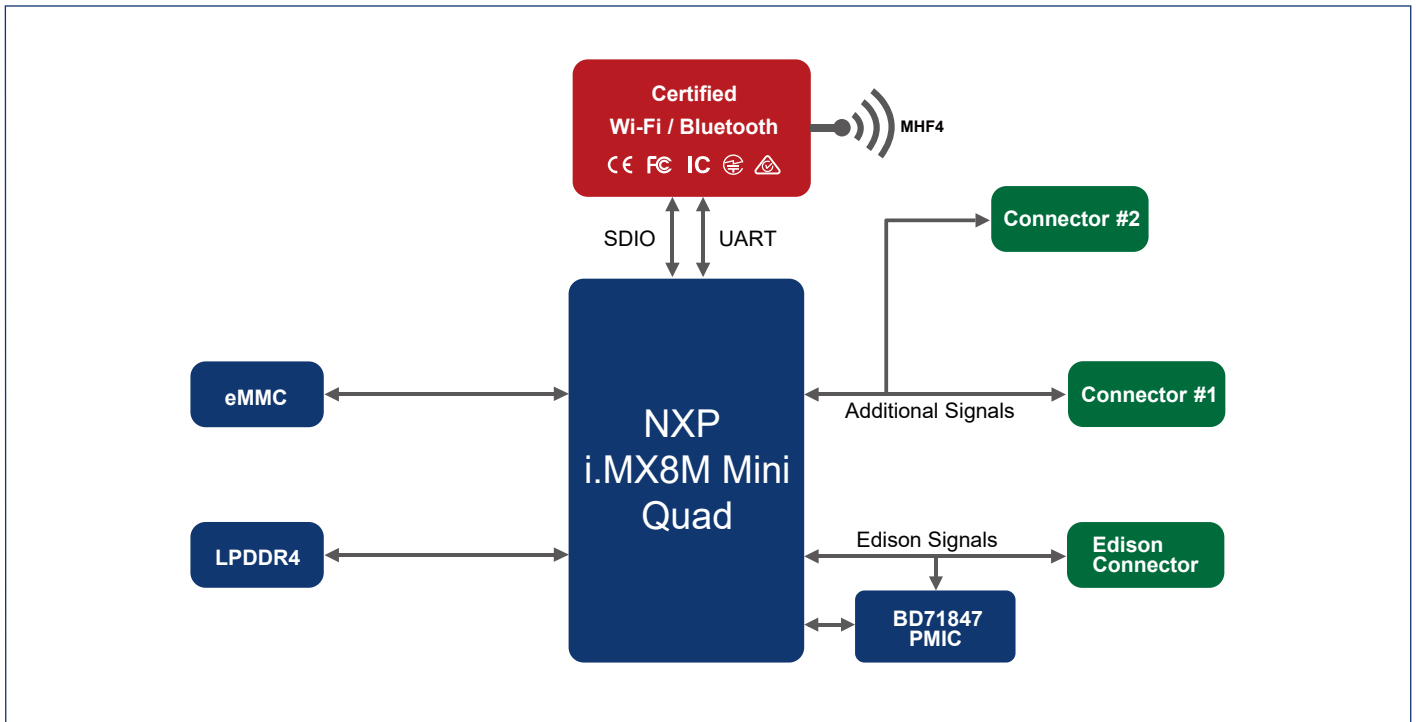

Environmental and Mechanical

Dimensions	37 x 40 mm / 1 5/8 x 1 5/8 inch
Form Factor	PICO Compute Module
Weight	8 grams
Temperature	Commercial: 0° to +60°C Industrial: -40° to +85°C
Relative Humidity	10 to 90 %
MTBF	>100 000 Hours
Shock	50G/25ms
Vibration	20G/0-600Hz

Power Specifications

Power Input	4.25-5.25 VDC
Power Consumption	Depending on Configuration

Order Information :

PICO-IMX8MMx-xx-Rxx-Exx-XXXX-xx-XXXX

	Code	Description
Processor	IMX8MMQ	NXP i.MX8M Mini Quad
Processor Speed	16	1.6GHz
	18	1.8GHz
Memory	R10	1GB LPDDR4
	R20	2GB LPDDR4
	R40	4GB LPDDR4
Storage	E16	eMMC 16GB
	EXX	eMMC other capacity
Wi-Fi / Bluetooth	-	-
	9377	Qualcomm QCA9377 802.11a/b/g/n/ac (2.4 + 5GHz) + Bluetooth
Temperature Range	-	Commercial Temperature range (0° to +60°C) (Default)
	TI	Industrial Temperature range (-40° to +85°C)
Custom ID	XXXX	Custom Part number ID for customized Software loader and special component (BOM)

Dimensions
(units in mm)

