

Iris Power PDTracII™

Continuous On-line Partial Discharge Monitoring for Medium and High Voltage Motors, Transformers, and Switchgear

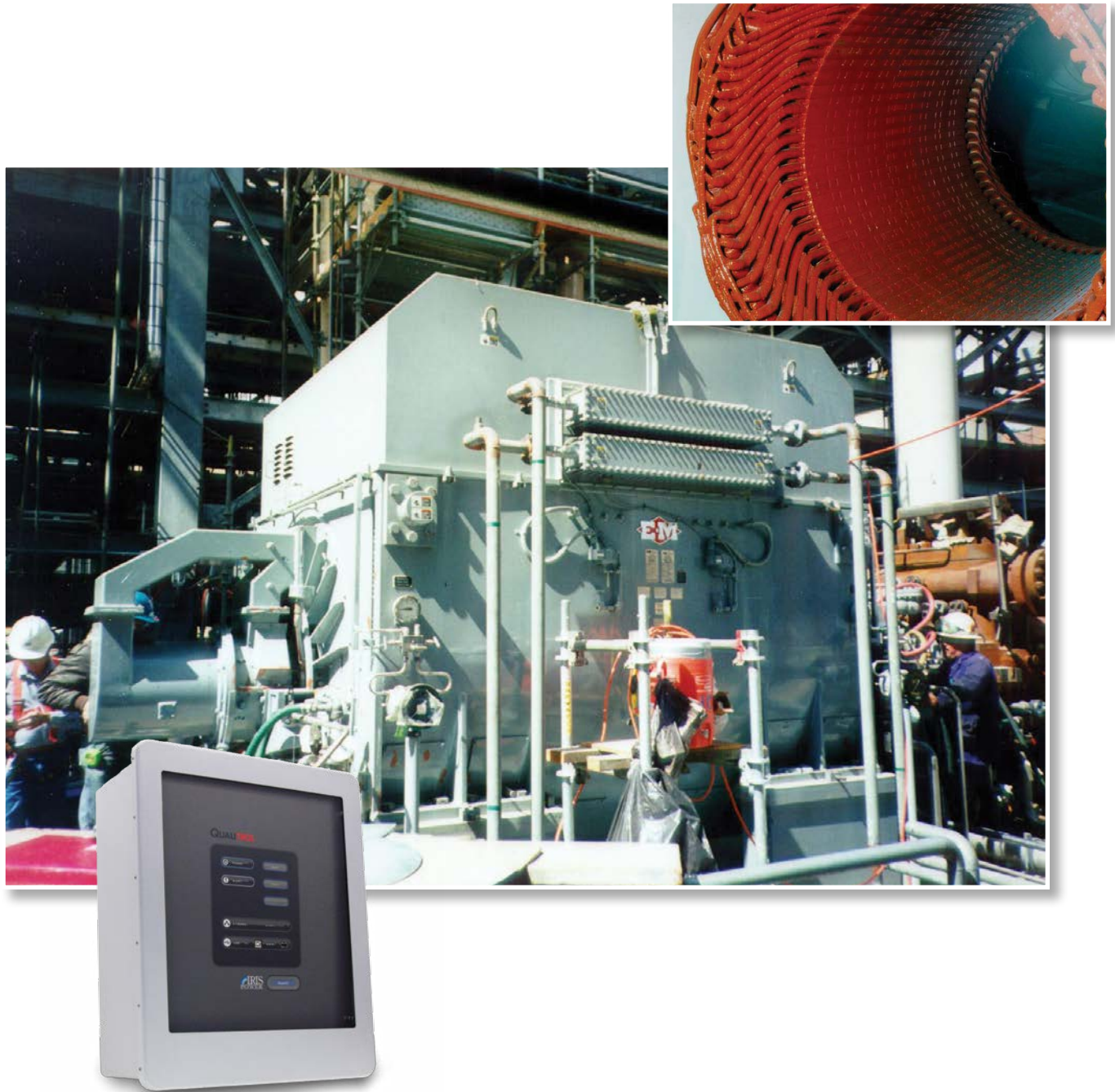

IRIS POWER PDTracII

IRIS POWER PDTracII SYSTEM

The Iris Power PDTracII system is an economical means of providing automated, continuous partial discharge (PD) measurement for motors, generators, switchgear, and dry type transformers. The Iris Power PDTracII system consists of three permanently installed capacitive couplers (one per phase), an Iris Power PDTracII monitor, with built in networking capability. The PDTracII can operate "stand alone" with only periodic downloading of archived PD data or it can be networked with the plant computer.

The Iris Power PDTracII is a third generation continuous on-line monitor that provides maintenance professionals with an opportunity to automate PD testing. The Iris Power PDTracII monitor also allows for the possibility of integrating important operating conditions needed for trending PD activity, and can trigger a remote alarm, indicating the need for a more detailed analysis. The monitor uses the same proven 80 pF capacitive sensors that have been permanently installed on motors, generators, and switchgear (3.3kV and higher) over the last 20 years by utilities and other industries around the world.

The Iris Power PDTracII monitor includes our unique and rigorously researched methods to overcome the electrical interference (noise) typical in most plant environments. This ensures reliable and repeatable measurements with a low probability of false alarms. The collected data can be easily interpreted by maintenance professionals after participating in a 2-day training seminar offered by Qualitrol-Iris Power's experts. The user's assessment of motor and generator insulation systems using on-line PD testing is greatly enhanced by access to Iris Power's extensive PD database of over 272,000 test results. The collective experience and results of our clients are regularly summarized in statistical tables, available to all users. This is a service unique to Qualitrol-Iris Power and its clients and ensures objective interpretation of insulation condition.

Facilities that have existing "single-ended" bus coupler installations can easily install the Iris Power PDTracII monitor by connecting it to the existing sensor termination panel within the plant. This does not require an outage and the installation effort is limited to

providing power to the monitor, wiring the alarm and/or sensor, and running a communication link to a local control room computer or an Ethernet LAN/WAN.

Apparatus not previously equipped with Iris Power capacitive couplers must have the 80 pF PD sensors installed during a suitable outage.

The Iris Power PDTracII monitor continuously collects PD data and archives data which are used to produce 2D and 3D (phase resolved) plots as well as summary numbers (Qm and NQN), which are used for trending and comparison with similar machines. Using the Windows™-based software, the archived PD data can be downloaded locally over a USB port, or remotely using Ethernet (TCP/IP) network communication.

Important operating conditions such as ambient humidity, stator winding or equipment temperature, voltage, and/or ambient temperature can be recorded and stored with the archived PD data. These parameters are useful for in-depth analysis and trending of the partial discharge activity.

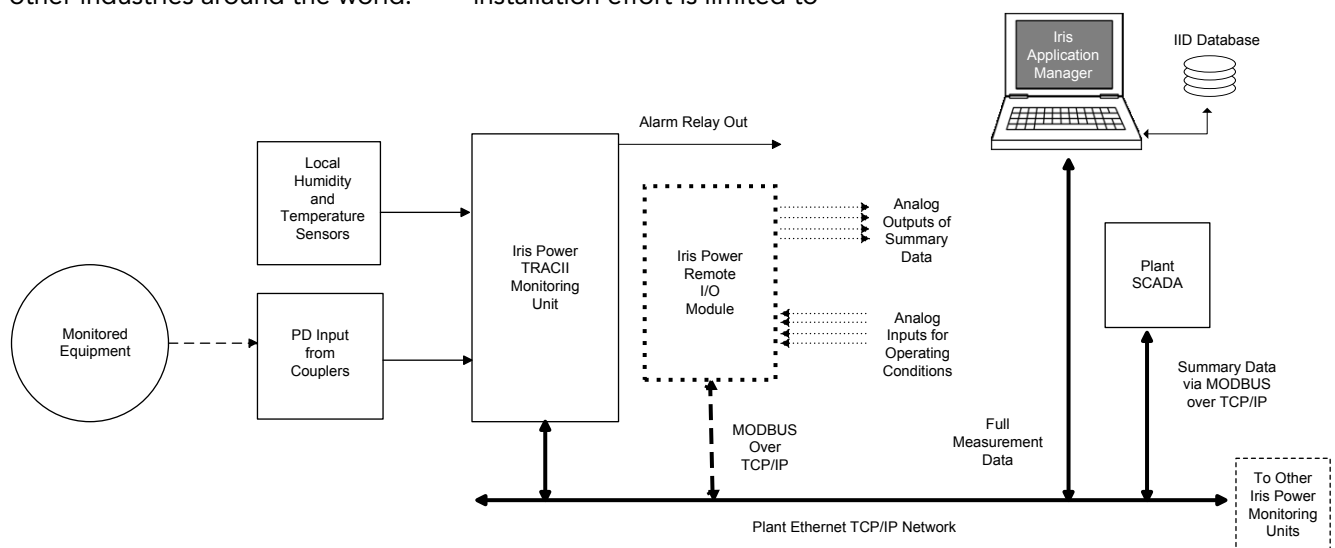

IRIS POWER PDTracII



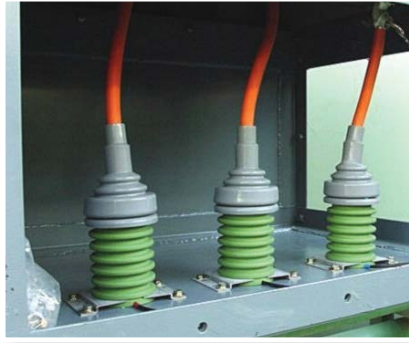

FEATURES

- The Iris Power PDTracII monitor contains superior noise separation technology based on filtering and pulse shape analysis, reliably distinguishing partial discharges from electrical interference (noise) in order to prevent false indications (alarms) when the monitored equipment is connected to the power system by >30m of power cable.
- Robust continuous monitor tested to withstand harsh plant conditions. Modular hardware and easy connections to facilitate field repairs and upgrades
- Data collected by the Iris Power PDTracII monitor is compatible with the existing patented TGA/PDA technology. Users with existing sensor installations can commission the system without a machine outage. Data is easily confirmed and further analyzed with the Iris Power TGAB™ or Iris Power PDA-IV™ portable monitors.
- The Iris Power monitor PDTracII is continuously collecting and periodically archiving PD data for download on 3 sensitivity ranges – a User Specified range, a range that Automatically adjusts to current PD levels, and a range suitable for evaluating PD Alert conditions.
- The Alert testing range ensures minimal intervention by maintenance personnel. In response to a PD alert, users can review the pulse height analysis plots, and the 24-window phase resolved PD plots using basic interpretation to confirm the cause of the alert. Alert levels are preset based on the Iris Power database of over 272,000 test results.
- Alert Output is a dedicated relay fitted within the monitor enclosure that can activate a remote indicator of high PD alert conditions. The alert conditions are configurable through the operating software. The alert output may be connected to a plant monitoring system.
- The Iris Power PDTracII monitor is equipped with ambient sensor input modules to enhance data gathering for trending and analysis. Using an optional sensor, ambient temperature and ambient humidity can be recorded along with the PD data readings.
- USB memory stick port for downloading stored data without a laptop computer.
- Qualitrol-Iris Power has extensive experience with continuous on-line PD monitoring. Over 2,000 continuous on-line PD monitors have been installed.
- Networking with an Ethernet port for remote diagnostics, downloading, configuration with Iris Power software.
- Modbus over Ethernet protocol included for interfacing to third party applications to obtain machine operating state and provide summary PD data.



Installed Capacitive Couplers

OPTIONS

- Remote inputs with 8 analog points proportional to operating conditions such as equipment temperature, voltage, current, or power. These conditions are recorded for trending and analysis.
- Remote outputs with 6 analog outputs proportional to the level of PD activity (+Qm and -Qm). This is applicable in situations where the user is interested in having the real-time PD activity acquired by their DCS or control system.
- Local ambient humidity and temperature sensor.
- C-UL-US Hazardous location, with stainless steel IP66 enclosure. For use in North American markets. PDTracII has markings Class 1, Division 2, Groups A, B, C, D based on ISA 12.12.01-2010 and CSA C22.2 NO. 213. 
- ATEX/IECEx Hazardous location, with stainless steel IP66 enclosure. For use in Global markets. PDTracII with markings II 3 G Ex nA nC IIC T5 Gc in compliance with EN 60079-0:2009, EN 60079-15:2010, IEC 60079-0:2010 Edition 5 and IEC 60079-15:2010 Edition 4. 

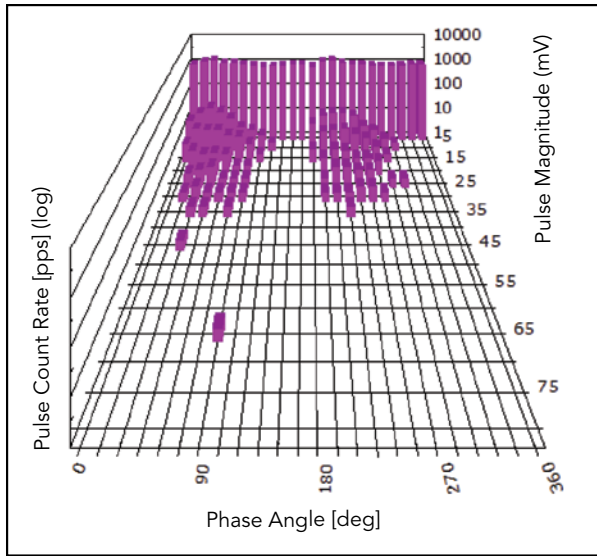
- INMETRO Hazardous location, with stainless steel IP66 enclosure. For use in Brazilian markets. PDTracII with markings BR-Ex nA nC IIC T5 according to Portaria 179:2010 
- Other country certifications may be available.

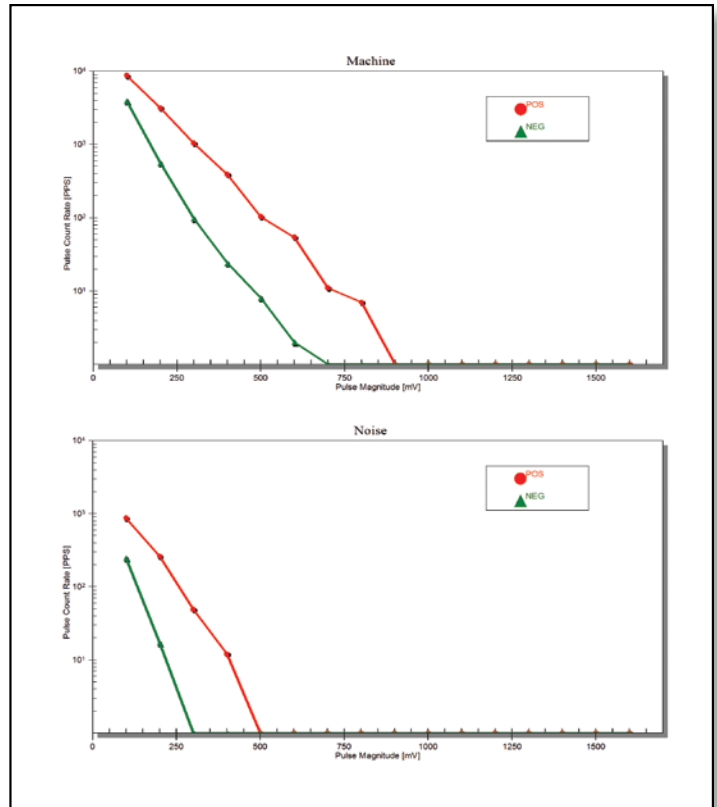

Phase-resolved PD output



PD Pulse Magnitude Output

WHAT IS PARTIAL DISCHARGE?

Partial discharges (PD) are small electrical sparks that occur within the high voltage electrical insulation in stator windings, dry type transformers, and switchgear. PD occurs whenever there are small air gaps or voids in or on the surface of the insulation. Normally, well-made apparatus that are in good condition display very little PD activity. However, over 60 years experience has shown that as

insulation deteriorates from vibration, operation at high temperatures, or contamination from oil, moisture and other chemicals, the PD activity will increase by a factor of ten or more. Thus, on-line PD monitoring detects the main root causes of failure. Since PD monitoring can be performed during normal apparatus operation, and generally gives two or more years of warning indicating a risk of failure, on-line PD monitoring has

become a very powerful tool for predictive maintenance.

Some benefits of PD monitoring of the stator winding are:

- increased availability of machines
- plan maintenance based on actual conditions
- significant reduction of in-service failures.

Iris Power PDTracII, Iris Power PDTracPro, Iris Power PDA-IV, Iris Power TGA-B are trademarks of Qualitrol-Iris Power. Windows is a registered trademark of Microsoft Corporation in the United States and other countries.

QUALITROL-IRIS POWER HAS BEEN THE WORLD LEADER IN MOTOR AND GENERATOR WINDING DIAGNOSTICS SINCE 1990, PROVIDING A FULL LINE OF ON-LINE AND OFF-LINE TOOLS, AS WELL AS COMMISSIONING AND CONSULTING SERVICES.



A **QUALITROL** Company

www.irispower.com

www.qualitrolcorp.com

Iris Power LP
 3110 American Drive
 Mississauga, ON, Canada L4V 1T2
 Phone: +1-905-677-4824
 Fax: +1-905-677-8498
 Sales.iris@qualitrolcorp.com

Qualitrol Company LLC
 1385 Fairport Road
 Fairport, NY, USA 14450
 Phone: +1-585-586-1515
 Fax: +1-585-377-0220



QUALITROL
 Defining Reliability

Ver 9 • 7/14